

MODEL : SD-205 [Superlite Check Valve]

Connection : JIS 10K, ANSI 150, PN 16

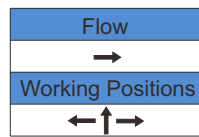

Small, lightweight, and easy to maintain.
Maintenance free and prevent pressure drop
Material : SS304, SS316



- ◆ Suitable for : 1. Water
- 2. Oil
- 3. Gases

◆ MATERIAL LIST

NO		MATERIAL	QTY
1	BODY	SUS304 SUS316	1
2	CLAPPER	SUS304 SUS316	1
3	BODY SEAT	VITON PTFE	2
4	CLAPPER SEAT	VITON PTFE	1
5	O-BOLT	304SS SUS316	1

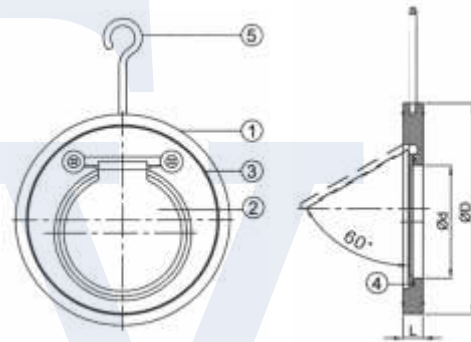

◆ DIMENSIONS (mm)

SIZE	1/2"	3/4"	1"	1-1/4"	1-1/2"	2"	2-1/2"	3"	4"	5"	6"	8"	10"	12"	14"	16"	18"	20"	22"	24"	26"	
d	8	9	12	16	21	30	42	50	72	93	113	142	190	211	260	306	358	408	450	485	520	
D	10K	55	60	70	80	85	104	124	134	155	190	220	270	325	370	415	475	530	580	640	690	745
	150LB	47	56	66	76	85	104	124	134	174	190	220	278	340	409	448	510	548	605	657	715	770
L	14	14	14	14	14	14	14	14	18	18	20	27	29	35	38	45	55	65	70	70	70	
Weight	0.6	0.6	0.9	1	1	1.2	1.6	1.8	2.5	3.7	5.5	11	12.8	21.7	31.1	39	61	85	125	150	190	

Specification is subject to change without prior notice